

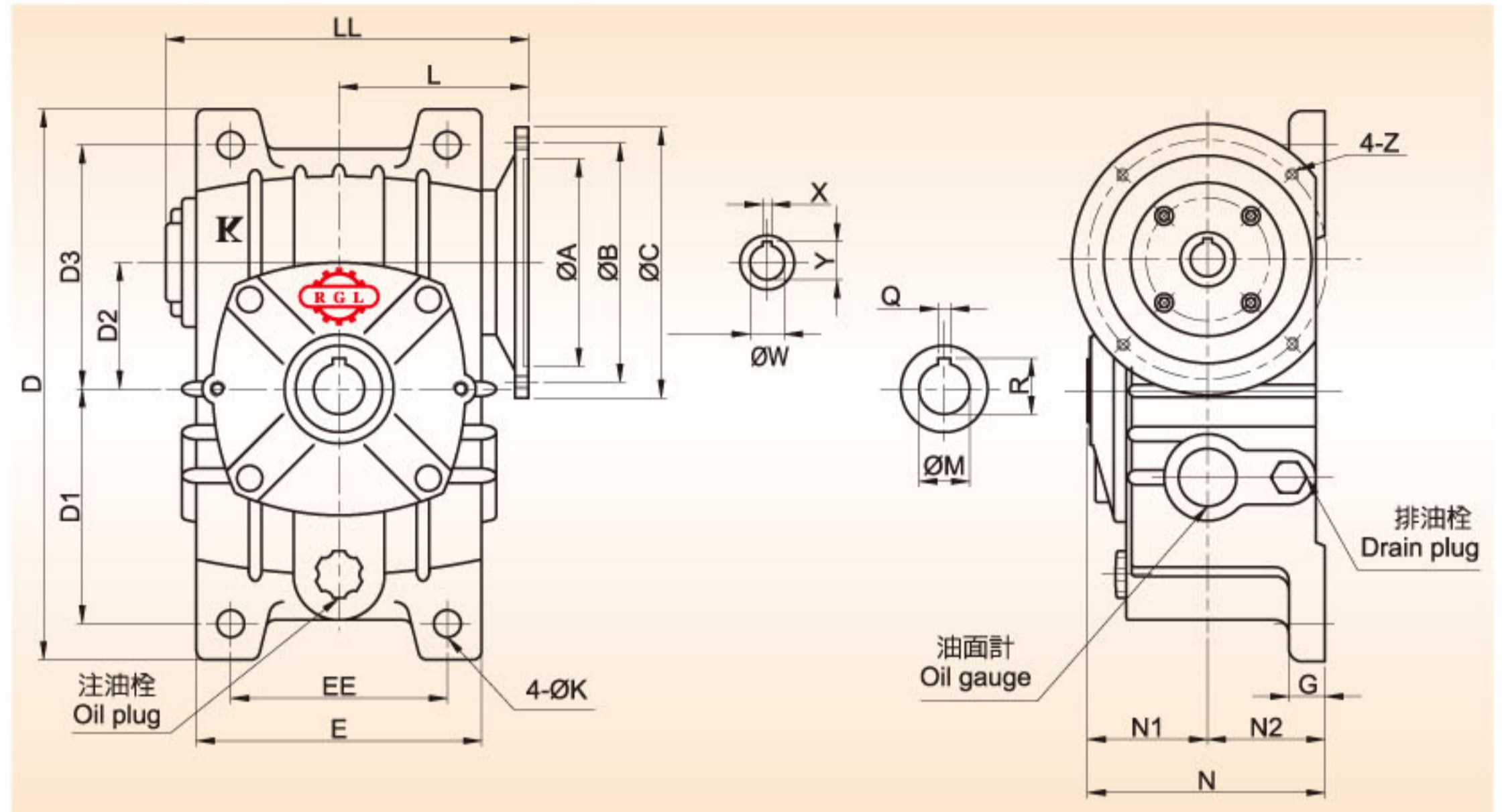

◀ Type: KOE ▶



KOE50-155



● 尺寸表 Dimensions ●

型號 SIZE	LL	L	N1	N2	N	D1	D2	D3	D	EE	E	G	K
50	154	81	50	50	100	93	50	102	220	90	126	14	11
60	160	85	56	55	111	105	60	120	260	100	126	15	11
70	196	102	66	65	131	120	70	135	295	120	156	20	15
80	217	113	70	70	140	130	80	150	320	140	176	20	15
100	280	148	89	90	179	155	100	180	375	190	226	27	15
120	318	165	99	100	199	185	120	215	450	220	266	30	18
135	367	188	106	110	216	210	135	235	495	260	306	30	18
155	395	203	138	140	278	145	155	265	456	290	336	36	20

型號 SIZE	馬力 HP		馬達盤 MOTOR FLANGE				入力孔 INPUT BORE			出力孔 OUTPUT BORE			重量 (Kg)
	1/10~ 1/30	1/40~ 1/60	A	B	C	Z	W	X	Y	M	Q	R	
50	1/4	1/8	110	130	160	M8	11	4	12.5	20	5	22	9
60	1/2	1/4	110	130	160	M8	11 14	4 5	12.5 16	25	7	28	12
70	1	1/2	110 130	130 165	160 200	M8 M10	14 19	5 6	16 21.5	30	7	33	19
80	2	1	130	165	200	M10	19 24	6 8	21.5 27	35	10	38.5	24
100	3	2	130 180	165 215	200 250	M10 M12	24 28	8	27 31	40	12	43.5	41
120	5	3	180	215	250	M12	28	8	31	45	12	48.5	61
135	7-1/2	5	180 230	215 265	250 300	M12	28 38	8 10	31 41	60	15	65	92
155	10	7-1/2	230	265	300	M12	38	10	41	70	18	76	129

註：#175-250 接單定製
(#175~250 can be customized)

● 軸配置及旋轉方向 Shaft Arrangement and Rotation Direction ●



LCO

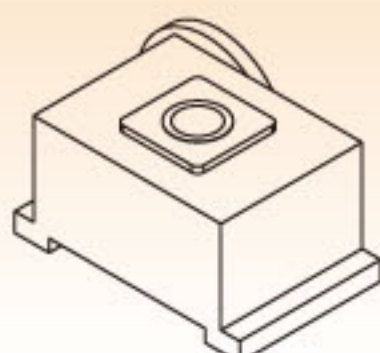

RCO

