

子母型蝸輪減速機-BHE系列

Two-stage worm gear reducer - BHE series
(worm-worm)

◀ Type: BHE ▶

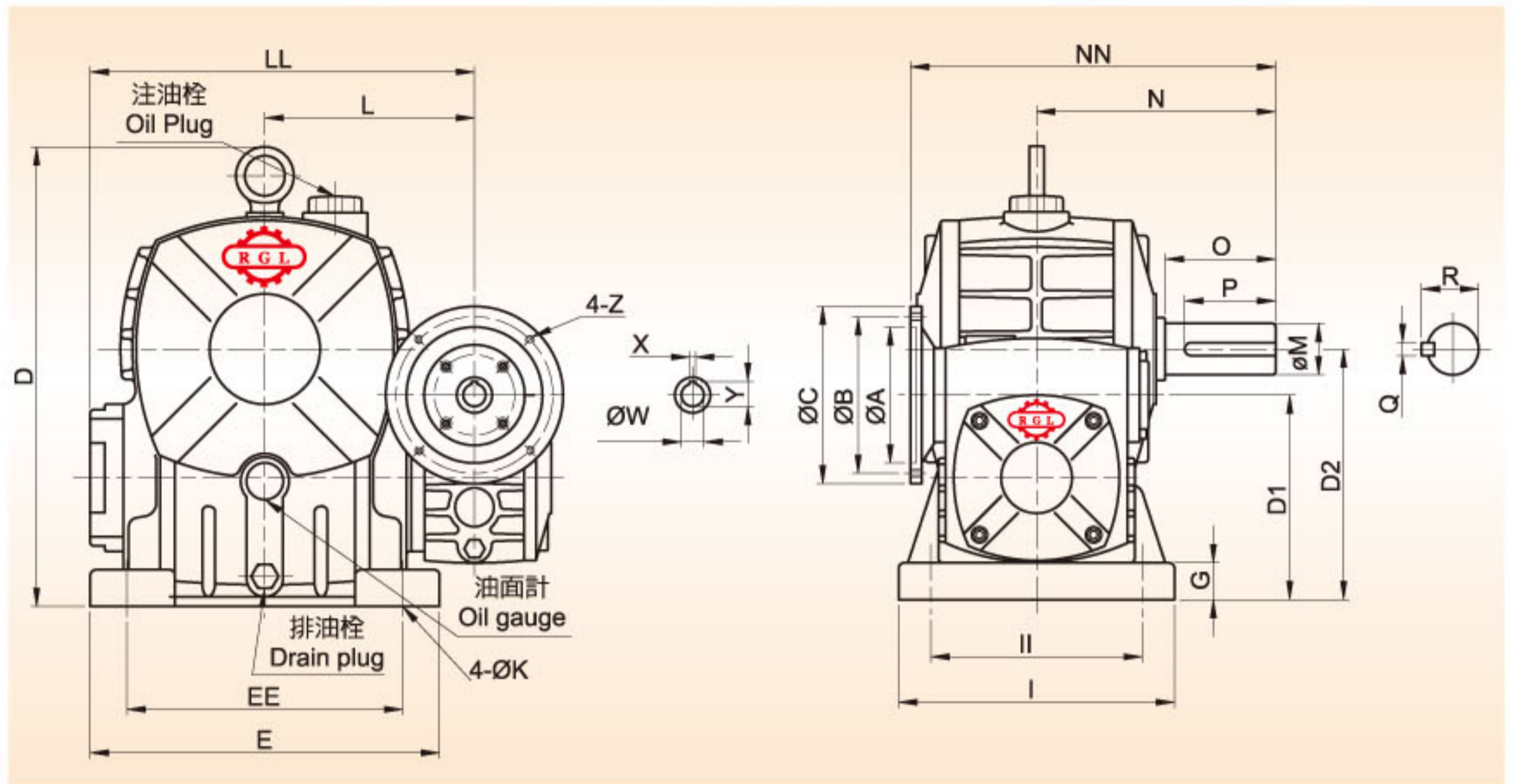

尺寸表 Dimensions

型號 SIZE	LL	L	NN	N	D1	D2	D	EE	E	II	I	G	K
80	239	135	280	140	130	160	265	180	220	135	170	20	15
100	293	161	255	170	160	200	362	220	270	155	190	25	15
120	340	185	291	190	190	240	424	260	320	180	230	30	18
135	401	215	335	210	215	270	481	290	350	200	250	30	18
155	449	257	410	252	235	290	512	320	380	220	280	36	20
175	513	290	428	262	280	335	577	350	410	250	310	37	20
200	548	310	493	305	310	375	650	350	420	290	360	42	27
225	599	329	523	335	325	415	702	390	460	330	410	45	27
250	660	365	563	360	355	450	755	440	520	380	460	50	27

型號 SIZE	馬力 HP		馬達盤 MOTOR FLANGE				入力孔 INPUT BORE			出力軸 OUTPUT SHAFT					重量 (Kg)
	1/100~ 1/900	1/1000~ 1/3600	A	B	C	Z	W	X	Y	O	P	M	Q	R	
80	1/4	1/8	110	130	160	M8	11	4	12.5	65	60	32	10	35.5	26
100	1/2	1/4	110	130	160	M8	11 14	4 5	12.5 16	75	70	38	10	41.5	47
120	1	1/2	110 130	130 165	160 200	M8 M10	14 19	5 6	16 21.5	85	80	45	12	48.5	74
135	2	1	130	165	200	M10	19 24	6 8	21.5 27	95	90	55	15	60	100
155	3	2	130 180	165 215	200 250	M10 M12	24 28	8 8	27 31	110	105	60	15	65	132
175	5	3	180	215	250	M12	28	8	31	110	105	65	18	71	194
200	7-1/2	5	180 230	215 265	250 300	M12	28 38	8 10	31 41	125	120	70	20	76	251
225	10	7-1/2	230	265	300	M12	38	10	41	140	135	80	20	86	315
250	15	10	230 250	265 300	300 350	M12 M16	42	12	45	155	150	90	24	98	395

軸配置及旋轉方向 Shaft Arrangement and Rotation Direction

